

THIS DRAWING IS UNPUBLISHED. RELEASED FOR PUBLICATION  
 © COPYRIGHT BY TYCO ELECTRONICS CORPORATION. ALL RIGHTS RESERVED.

LOC		DIST		REVISIONS			
P	LTR	DESCRIPTION	DATE	DWN	APVD		
FT	0	T	REVISED PER 0G3B-0956-04	11/22/04	SS	GS	

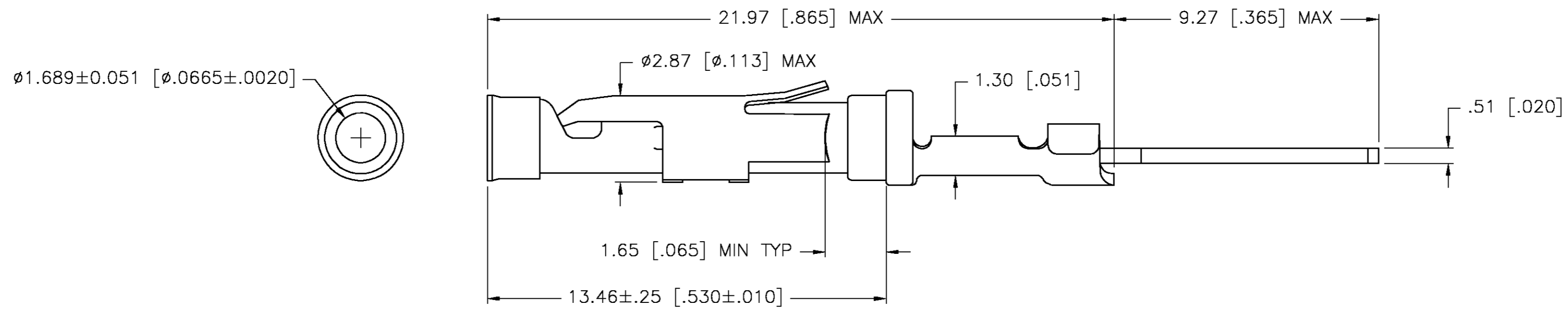
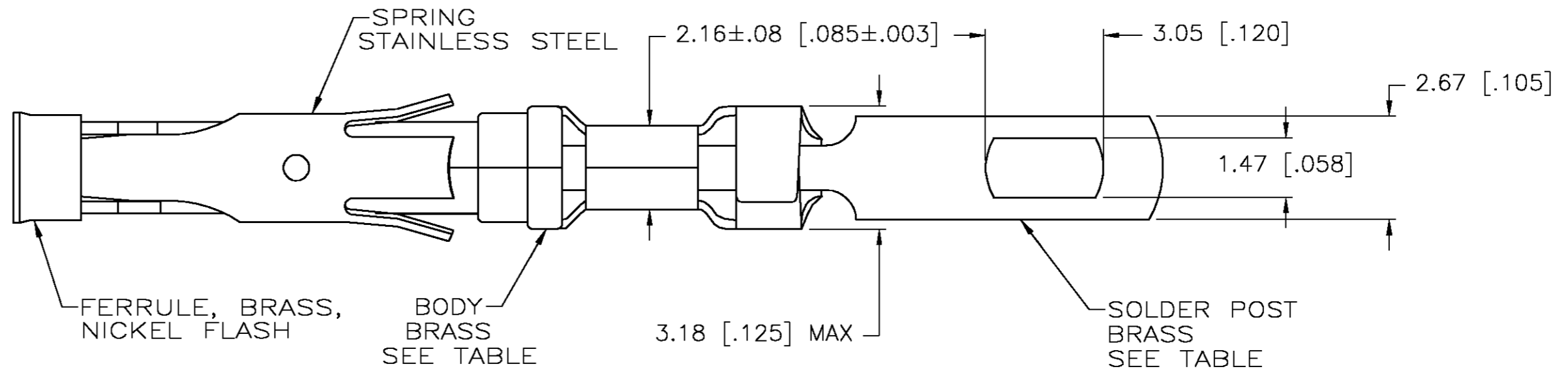

- ① 0.76µm [.000030] MIN GOLD PER MIL-G-45204 ON MATING END FOR A LENGTH OF 5.08 [.200] MIN WITH A UNIFORM GRADIENT TO 0.25µm [.000010] MIN GOLD PER MIL-G-45204 ON THE REMAINDER OVER 0.76µm [.000030] MIN NICKEL PER QQ-N-290.
- ② 1.27µm [.000050] MIN TIN-LEAD PER MIL-T-10727 OVER 0.76µm [.000030] MIN NICKEL PER QQ-N-290.
- ③ 2.54µm [.000100] MIN TIN-LEAD PER MIL-T-10727 OVER 1.27µm [.000050] MIN NICKEL PER QQ-N-290.
- ④ 2.54µm [.000100] MIN TIN PER MIL-T-10727 OVER 1.27µm [.000050] MIN NICKEL PER QQ-N-290.
- ⑤ 1.27µm [.000050] MIN TIN PER MIL-T-10727 OVER 0.76µm [.000030] MIN NICKEL PER QQ-N-290.

SMALL PACK	④	①	202237-8
STANDARD	④	①	202237-7
SMALL PACK	④	⑤	202237-6
STANDARD	④	⑤	202237-5
SMALL PACK	③	②	202237-4
SMALL PACK	③	①	202237-3
STANDARD	③	②	202237-2
STANDARD	③	①	202237-1
PACKAGING TYPE	SOLDER POST FINISH	BODY FINISH	PART NO

THIS DRAWING IS A CONTROLLED DOCUMENT.		DWN	31JUL91	Tyco Electronics Corporation Harrisburg, Pa 17105-3608
DIMENSIONS: mm [INCHES]		CHK	20SEP91	
TOLERANCES UNLESS OTHERWISE SPECIFIED:		APVD	20SEP91	
0 PLC ± - 1 PLC ± - 2 PLC ± 0.13[.005] 3 PLC ± - 4 PLC ± - ANGLES ± - FINISH SEE CALLOUTS		NAME	J. WESTMAN	
MATERIAL SEE CALLOUTS		PRODUCT SPEC		SOCKET ASSEMBLY, SOLDER POST, TYPE III+
		APPLICATION SPEC		SIZE
		WEIGHT	-	CAGE CODE
		CUSTOMER DRAWING		DRAWING NO
		SCALE	8:1	RESTRICTED TO
		SHEET	1 OF 1	REV
		REV	T	